

Lecture #37

Today: A little side excursion into nitty-gritty stuff: Storage management.

Scope and Lifetime

- *Scope* of a declaration is portion of program text to which it applies (is *visible*).
 - Need not be contiguous.
 - In Java, is static: independent of data.
- *Lifetime* or *extent* of storage is portion of program execution during which it exists.
 - Always contiguous
 - Generally dynamic: depends on data
- Classes of extent:
 - *Static*: entire duration of program
 - *Local* or *automatic*: duration of call or block execution (local variable)
 - *Dynamic*: From time of allocation statement (*new*) to deallocation, if any.

Explicit vs. Automatic Freeing

- Java has no explicit means to free dynamic storage.
- However, when no expression in any thread can possibly be influenced by or change an object, it might as well not exist:

```
IntList wasteful()  
{  
    IntList c = new IntList(3, new IntList(4, null));  
    return c.tail;  
    // variable c now deallocated, so no way  
    // to get to first cell of list  
}
```

- At this point, Java runtime, like Scheme's, recycles the object `c` pointed to: *garbage collection*.

Under the Hood: Allocation

- Java pointers (references) are represented as integer addresses.
- Corresponds to machine's own practice.
- In Java, cannot convert integers \leftrightarrow pointers,
- But crucial parts of Java runtime implemented in C, or sometimes machine code, where you can.
- Crude allocator in C:

```
char store[STORAGE_SIZE]; // Allocated array
size_t remainder = STORAGE_SIZE;

/** A pointer to a block of at least N bytes of storage */
void* simpleAlloc(size_t n) { // void*: pointer to anything
    if (n > remainder) ERROR();
    remainder = (remainder - n) & ~0x7; // Make multiple of 8
    return (void*) (store + remainder);
}
```

Example of Storage Layout: Unix

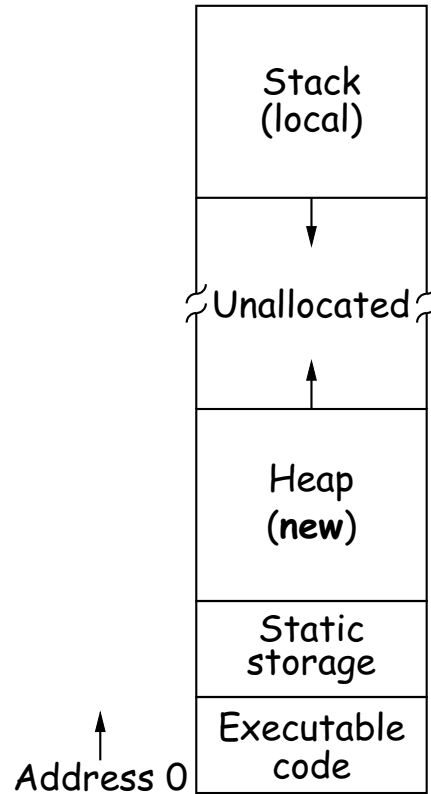

- OS gives way to turn chunks of unallocated region into heap.
- Happens automatically for stack.

Explicit Deallocating

- C/C++ normally require explicit deallocation, because of
 - Lack of run-time information about what is array
 - Possibility of converting pointers to integers.
 - Lack of run-time information about *unions*:

```
union Various {  
    int Int;  
    char* Pntr;  
    double Double;  
} X; // X is either an int, char*, or double
```

- Java avoids all three problems; automatic collection possible.
- Explicit freeing can be somewhat faster, but rather error-prone:
 - Memory corruption
 - Memory leaks

Free Lists

- Explicit allocator grabs chunks of storage from OS and gives to applications.
- Or gives recycled storage, when available.
- When storage is freed, added to a *free list* data structure to be recycled.
- Used both for explicit freeing and some kinds of automatic garbage collection.

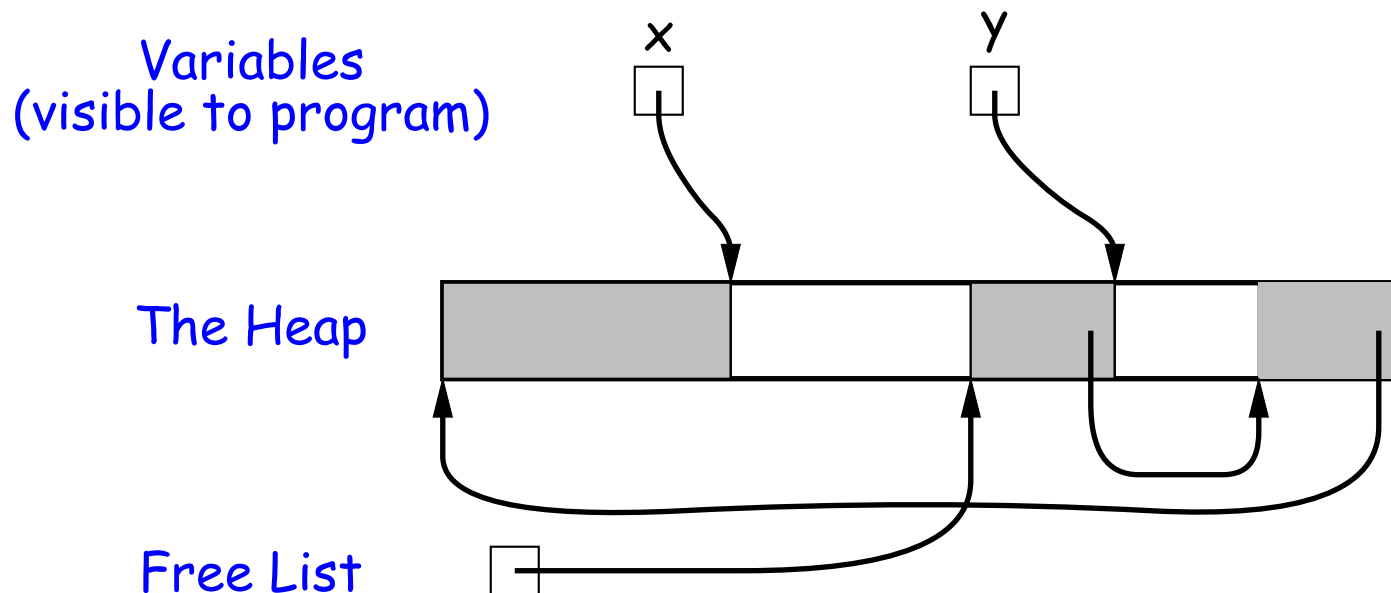

Free List Strategies

- Memory requests generally come in multiple sizes.
- Not all chunks on the free list are big enough, and one may have to search for a chunk and break it up if too big.
- Various strategies to find a chunk that fits have been used:
 - *Sequential fits*:
 - * Link blocks in LIFO or FIFO order, or sorted by address.
 - * Coalesce adjacent blocks.
 - * Search for *first fit* on list, *best fit* on list, or *next fit* on list after last-chosen chunk.
 - *Segregated fits*: separate free lists for different chunk sizes.
 - *Buddy systems*: A kind of segregated fit where some newly adjacent free blocks of one size are easily detected and combined into bigger chunks.
- Coalescing blocks reduces *fragmentation* of memory into lots of little scattered chunks.

Garbage Collection: Reference Counting

- Idea: Keep count of number of pointers to each object. Release when count goes to 0.

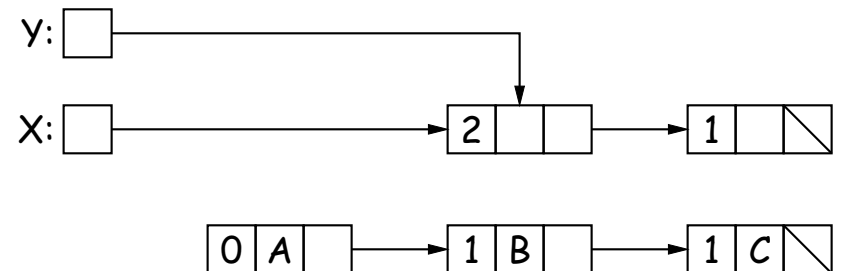
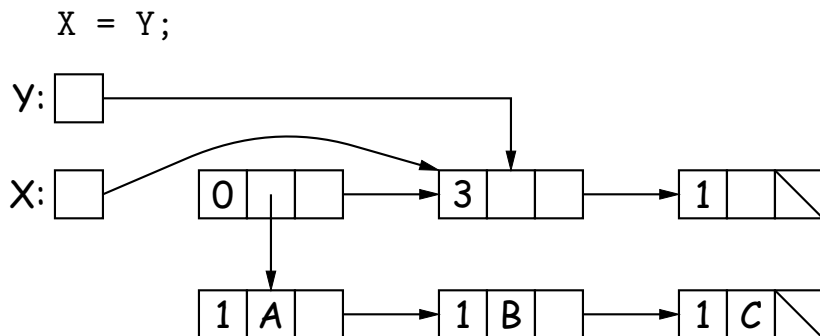
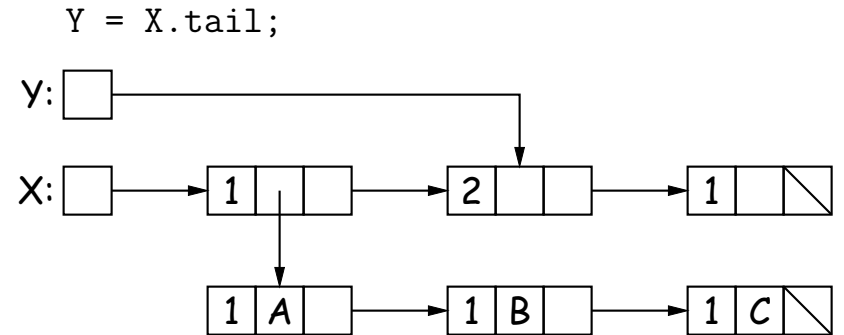
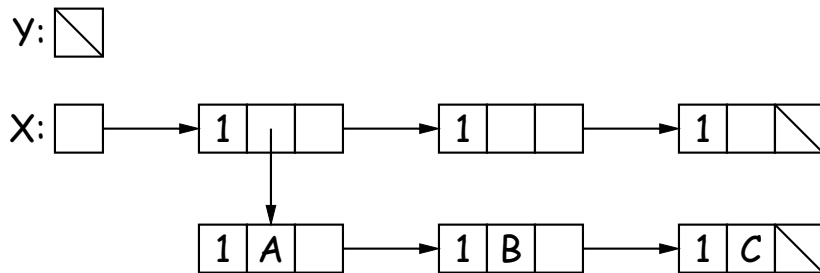

... etc., until:

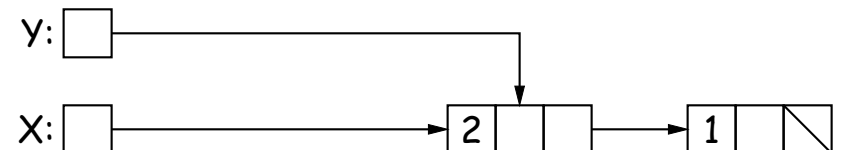

Garbage Collection: Mark and Sweep

Roots (locals + statics)

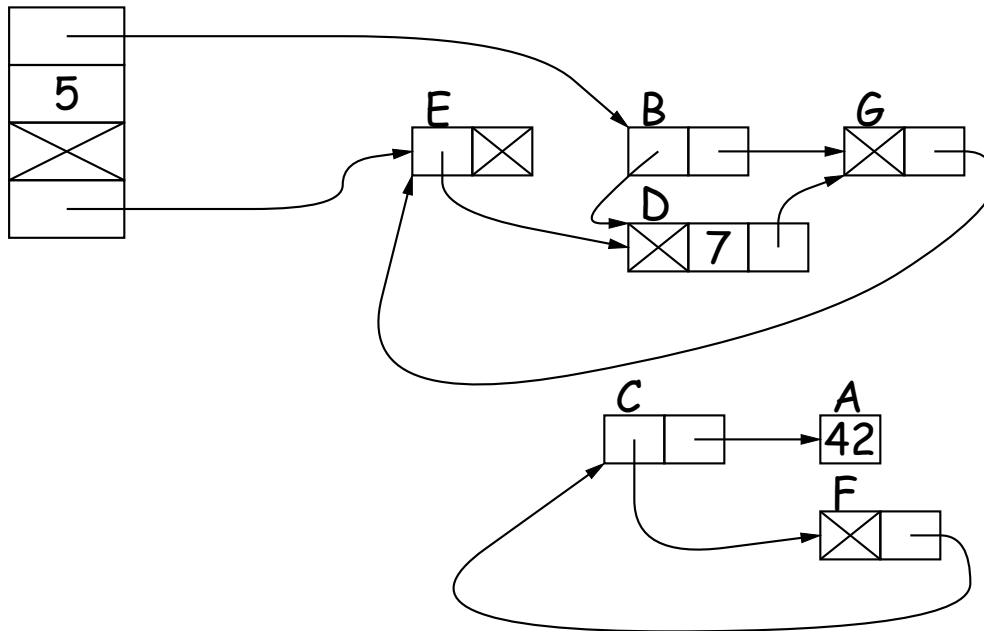

1. Traverse and **mark** graph of objects.
2. **Sweep** through memory, freeing unmarked objects.

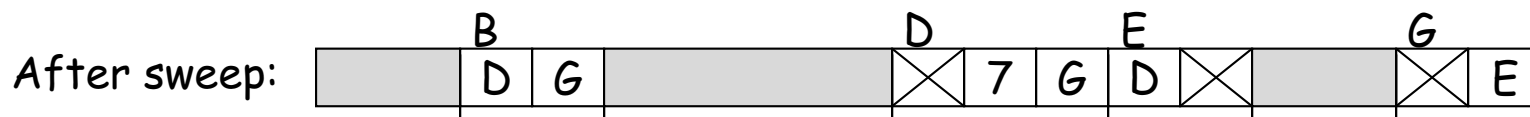
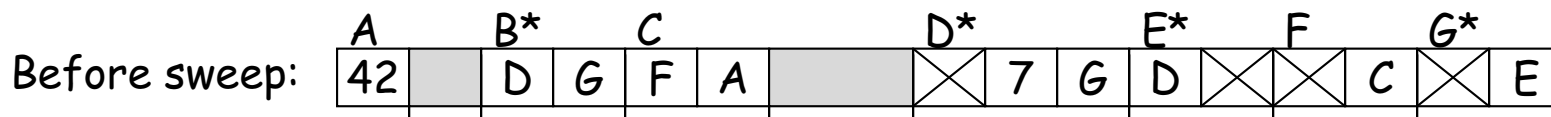

Cost of Mark-and-Sweep

- Mark-and-sweep algorithms don't move any existing objects—pointers stay the same.
- The total amount of work depends on the amount of memory swept—i.e., the total amount of active (non-garbage) storage + amount of garbage. Not necessarily a big hit: the garbage had to be active at one time, and hence there was always some “good” processing in the past for each byte of garbage scanned.

Copying Garbage Collection

- Another approach: *copying garbage collection* takes time proportional to amount of active storage:
 - Traverse the graph of active objects breadth first, *copying* them into a large contiguous area (called "to-space").
 - As you copy each object, mark it and put a *forwarding pointer* into it that points to where you copied it.
 - The next time you have to copy an already marked object, just use its forwarding pointer instead.
 - When done, the space you copied from ("from-space") becomes the next to-space; in effect, all its objects are freed in constant time.

Copying Garbage Collection Illustrated

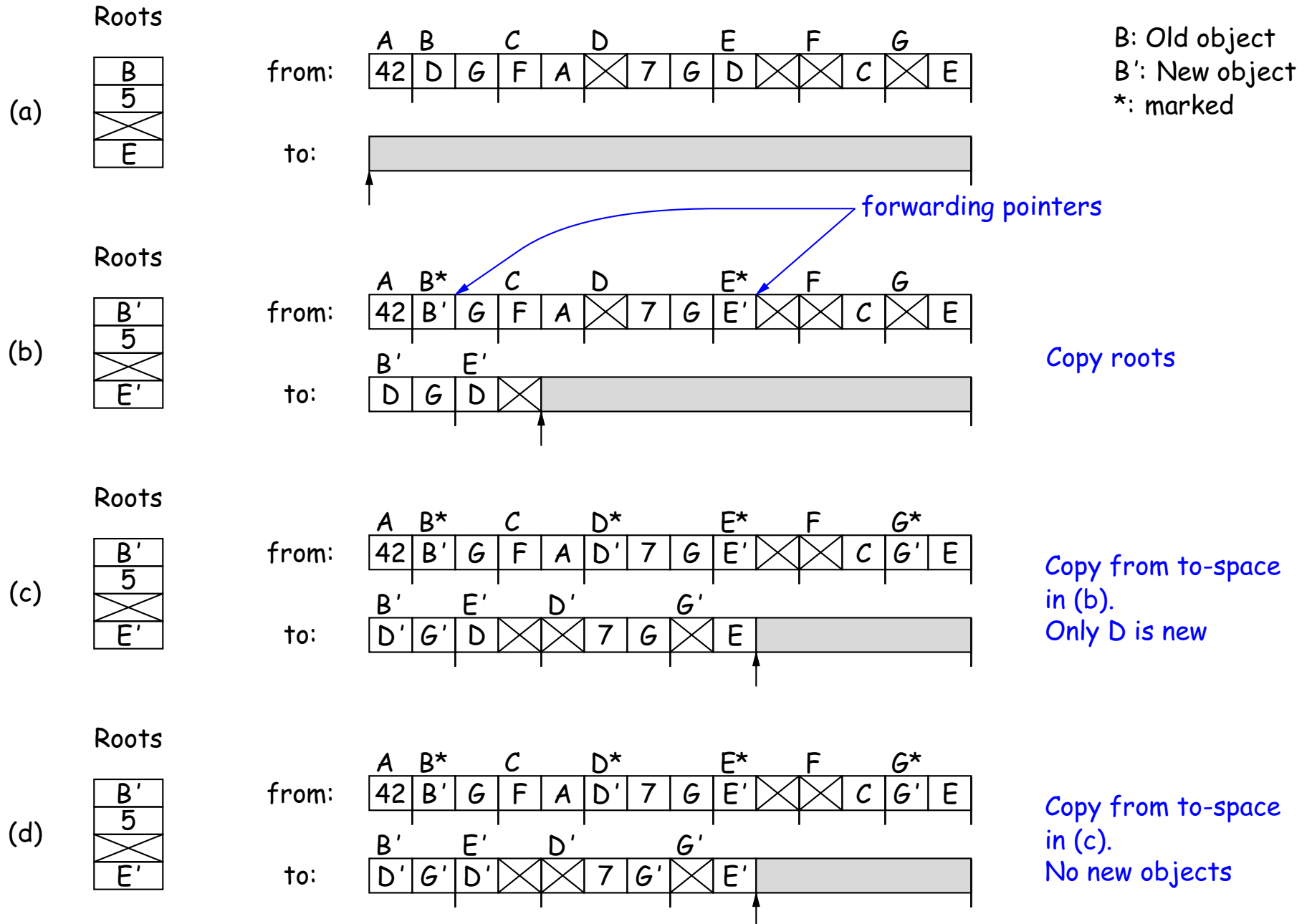

Most Objects Die Young: Generational Collection

- Most older objects stay active, and need not be collected.
- Would be nice to avoid copying them over and over.
- *Generational garbage collection* schemes have two (or more) memory spaces: one for newly created objects (*new space*) and one for “tenured” objects that have survived garbage collection (*old space*).
- A typical garbage collection collects only in new space, ignores pointers from new to old space, and moves objects to old space.
- As roots, uses usual roots plus pointers in old space that have changed (so that they might be pointing to new space).
- When old space full, collect all spaces.
- This approach leads to much smaller *pause times* in interactive systems.

There's Much More

- These are just highlights.
- Lots of work on how to implement these ideas efficiently.
- *Distributed garbage collection*: What if objects scattered over many machines?
- *Real-time collection*: where predictable pause times are important, leads to *incremental* collection, doing a little at a time.